

BOM LIST			
ITEM	PART NAME	Q'ty	NOTES
1	PLASTIC HOOD	2	ABS
2	BOLT	2	#4-40
3	NUT	2	M3
4	LONG SCREW	2	M3
5	SMALL WASHER	2	
6	SHORT SCREW	2	M3
7	BIG WASHER	2	M3

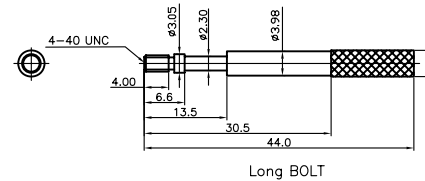
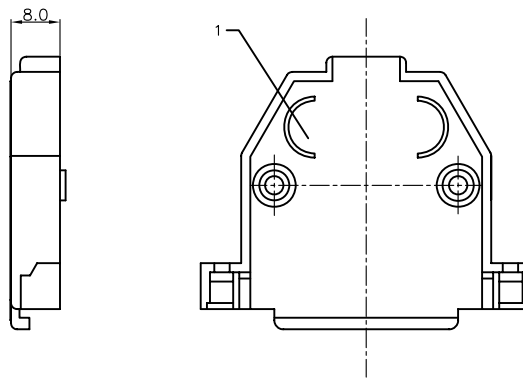

REV.	DESCRIPTION	DRAWN	CHECKED	APPROVED

NOTES:
 1. PART NUMBER CODE:
 DS1046 - 25 X X X

- Bolt type
 L: Long
 S: Short
- Packing type
 1: Mix packing
 2: Separation packing
- Cover Material
 C: Chromium Plated
- Positions
 25: 25pin

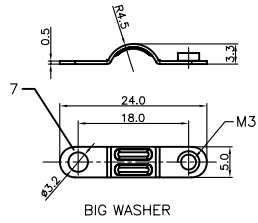
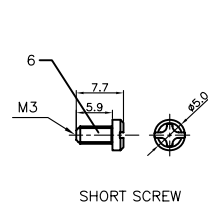
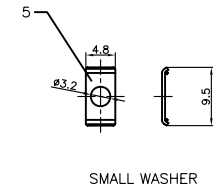
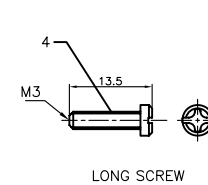
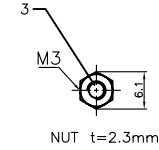
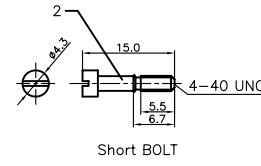

GENERAL TOLERANCE		ANGLE TOLERANCE		PROJECTION		TITLE	D-SUB 25pin Cover Chromium plated		
X.	± 0.60	X.	$\pm 5^\circ$	UNITS	mm	SHEET SIZE	A4	SERIES	DS1046 SERIES
.X	± 0.38	.X	$\pm 3^\circ$	DN-25C					
.XX	± 0.25	.XX	$\pm 2^\circ$						
DRAWING TYPE		COSTOMER							
SCALE		1:1	SHEET	1 OF 1					
DRAWING NO.		C-DS1046-25XXX							